

# Otari CM Series

## SPECIFICATIONS

### CM-20TI TITLE SHEET INSERTER

**Operation Speed:** 20 case per minute  
**Title Sheet Magazine Capacity:** 100 sheets  
**Case Supply/Ejection Method:** Supply = manual. Ejection = automated (case opened)  
**Supported Cases:** Tall case (regular, slim & half)  
**Title Sheet Specifications:** Dimensions (W x H) = 273<sup>+0.5</sup> x 183<sup>+0.5</sup> mm (regular), 266<sup>+0.5</sup> x 183<sup>+0.5</sup> mm (slim). Material = 60 lb. cover stock, both sides coated. Single side print  
**Dimensions (W x H x D):** 405 x 420 x 735 mm  
**Weight:** 31 kg  
**Power & Power Consumption:** Single phase 100-240 VAC ±10%, 50/60Hz. Less than 100 VA  
**Compressed Air Source:** Primary side pressure = min. 0.5 MPa (dry air)  
**Compressed Air Consumption:** max. 75 liters per minute (A.N.R.)  
**Vacuum Source:** Two internal ejectors

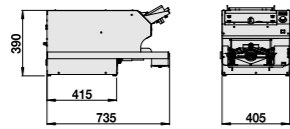

### CM-20CF CASE FEEDER

**Operation Speed:** 20 cases per minute  
**Case Magazine Capacity:** 100 cases (regular)  
**Supported Cases:** Tall case (regular & slim), Half case (requires conversion kit)  
**Dimensions (W x H x D):** 730 x 1530 x 687 mm  
**Weight:** 85 kg  
**Power & Power Consumption:** Single phase 100-240 VAC ±10%, 50/60 Hz. Less than 100 VA  
**Compressed Air Source:** Primary side pressure = min. 0.5 MPa (dry air)  
**Compressed Air Consumption:** max. 135 liters per minute (A.N.R.)  
**Vacuum Source:** Three internal ejectors

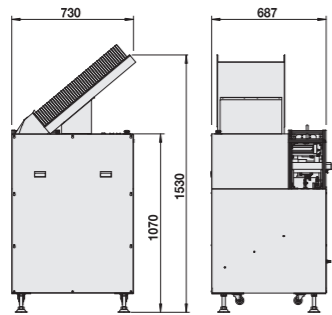

### CM-20DI/DIS DISC INSERTER

**Operation Speed:** 20 cases per minute  
**Disc Capacity:** DI = 100 x 2. DIS = 150 x 2 (depends on spindle length)  
**Supported Cases:** Tall case (regular & slim, Warner), Half case  
**Supported Disc:** ø12 cm disc  
**Dimensions (W x H x D):** 620 x 1170 x 757 mm (DIS)  
**Weight:** 78.5 kg (DIS)  
**Power & Power Consumption:** Single phase 100-240 VAC ±10%, 50/60 Hz. Less than 100 VA  
**Compressed Air Source:** Primary side pressure = min. 0.5 MPa (dry air)  
**Compressed Air Consumption:** max. 150 liters per minute (A.N.R.)  
**Vacuum Source:** Three internal ejectors

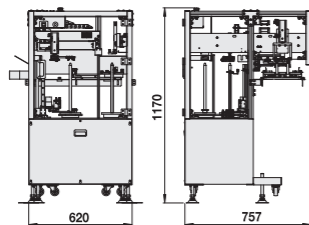

**Dimension of Supported Cases**  
 (No bend, warp or deformation. H x W x D)  
 Regular = 191 x 136 x 15 mm, Slim = 191 x 136 x 7.5 mm  
 Warner = 190 x 141 x 14 mm, Half = 125 x 142 x 10.5 mm

### CM-20CC CASE CLOSER

**Operation Speed:** 20 cases per minute  
**Supported Cases:** Tall case (regular & slim, double, Warner), Half case  
**Dimensions (W x H x D):** 500 x 1200 x 500 mm  
**Weight:** 52 kg  
**Power & Power Consumption:** Single phase 100-240 VAC ±10%, 50/60 Hz. Less than 100 VA  
**Compressed Air Source:** Primary side pressure = min. 0.5 MPa (dry air)  
**Compressed Air Consumption:** max. 25 liters per minute (A.N.R.)

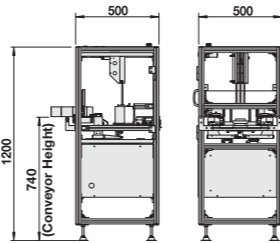

### CM-100DC/DC2 DISC CHECKER

**Operation Speed:** max. 110 cases per minute  
**Supported Cases:** Tall case (regular & slim, Warner), Half case  
 N.B. Disc shortage check for 2- or more disc set cases is not available.  
**Dimensions (W x H x D):** 1045 x 780 x 470 mm  
**Power & Power Consumption:** Single phase 100 VAC or 200 VAC ±15%, 50/60 Hz. Less than 150 VA

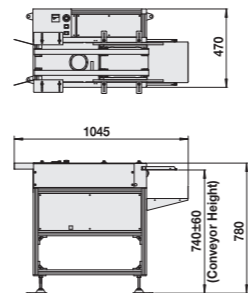

### CM-60CS CASE STACKER

**Operation Speed:** 60 cases per minute  
**Supported Cases:** Tall case (regular & slim, Warner), Half case  
**Dimensions (W x H x D):** 985 x 1390 x 1545 mm  
**Weight:** 95 kg  
**Power & Power Consumption:** Single phase 100 VAC ±15%, 50/60 Hz. Less than 100 VA  
**Compressed Air Source:** Primary side pressure = min. 0.5 MPa (dry air)  
**Compressed Air Consumption:** max. 170 liters per minute (A.N.R.)

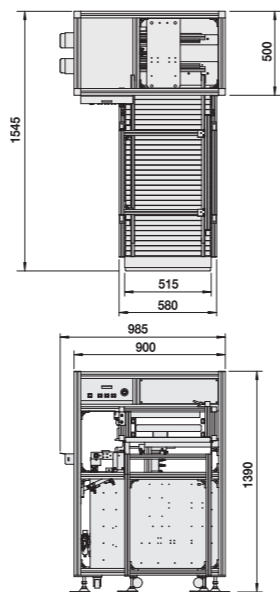

Specifications are subject to change without prior notice.

**Otari, Inc.**  
 4-33-3 Kokuryo-cho,  
 Chofu-shi, Tokyo  
 182-0022, Japan  
 Phone: +81/42-481-8626  
 Fax: +81/42-481-8633  
 e-mail: sales@otari.co.jp

**Otari Singapore Pte, Ltd.**  
 34 Jalan Jintan Singapore 229021  
 Phone/Fax: +65 6738-7807  
 e-mail: sales@otari.com.sg

**Otari U.S.A. Sales Inc.**  
 21110 Nordhoff Street, Suite G/H,  
 Chatsworth, CA 91311  
 Phone: (818) 734-1785  
 Fax: (818) 734-1786  
 e-mail: sales@otari.com

**OTARI**  
[www.otari.com](http://www.otari.com)

©2008 Otari, Inc. Printed in Japan (Ed1 2008-04 GK)

# Media Packaging Solutions OTARI



## CM-Series



**From Standalone Use to Automated Line**

**Modularized Compact Units Give You Flexibility and Expandability**

**Now Ready for BD and Game Card Packaging!**

The Otari CM system is the first media packaging line that grows with your production! It includes separate modules for precise title-sheet insertion, box feeding, case turn around, accurate media placing, case closing and stacking. All modules may also operate flexibly as standalones – semi or fully automated – and support a wide variety of media and cases.

In addition to "BD" kits for Blu-ray DVD disc packaging, new models and a "DS" kit are added to the CM-series to enable packaging of Game Cards.

Easy operation, low power and air consumption, a truly compact footprint, and Otari's typical rugged machine construction guarantee 24 hours of uninterrupted production every day.

# Otari CM-Series Media Packaging Solutions

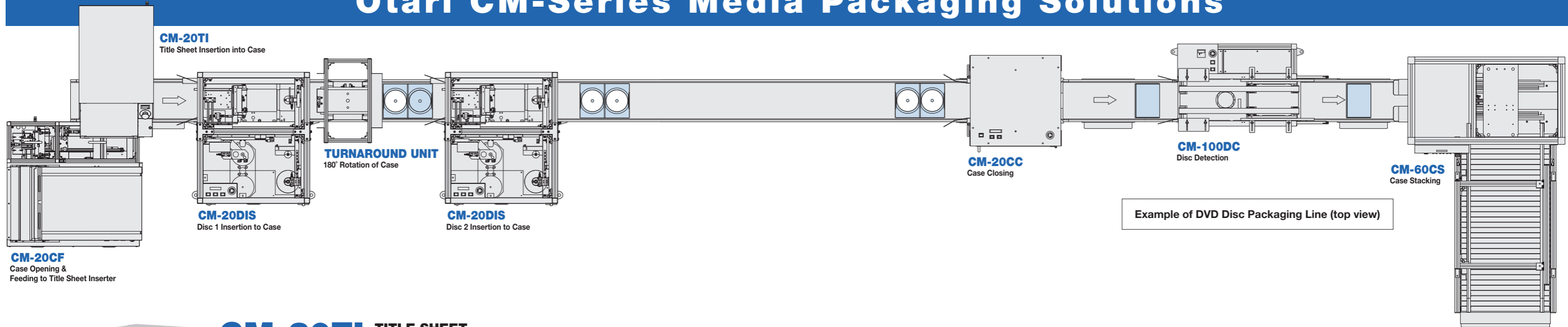

Example of DVD Disc Packaging Line (top view)

**CM-20CF**  
Case Opening & Feeding to Title Sheet Inserter



## CM-20TI TITLE SHEET INSERTER

The CM-20TI Title Sheet Inserter is a machine that specializes in the bothersome title sheet inserting process. Combined with the CM-20CF Case Feeder, the CM-20TI can fully automate all processes from case supply to title sheet insertion. The CM-20TI can be used as a semi-automatic standalone machine: when the operator manually inserts an opened case into the mechanism, the CM-20TI automatically inserts the title sheet fed from the magazine into the case and ejects it under the machine. The CM-20TI can be used for slim cases (when switching between case types, the widths of the magazine and case guide can be changed easily).

## CM-20CF CASE FEEDER

The CM-20CF Case Feeder is designed to be linked with the CM-20TI Title Sheet Inserter and to automate a series of operations from taking in and opening DVD cases to feeding them to the CM-20TI. The CM-20CF's case magazine can hold up to 100 cases. The title sheet set operation can be controlled by a button on the CM-20CF and you can start/stop the entire packaging system from the CM-20CF. Setup change for slim cases can be easily done without hand tools. The machine can handle half cases by attaching a conversion kit. As a standalone machine, the CM-20CF can be used to open and eject the cases.

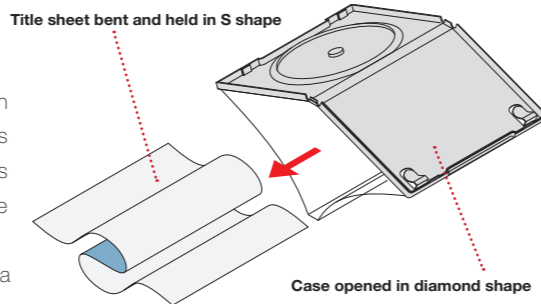

## CM-20DI/DIS DISC INSERTER

The Otari CM-20DI/DIS DVD Disc Inserter automatically inserts DVD discs into tall cases supplied on a conveyor from upstream machines (CM-20CF + CM-20TI) or by hand and ejects completed discs on a conveyor. There are two models according to disc supply method: CM-20DI and CM-20DIS. The CM-20DI adopts two disc supply magazines each of which can hold 100 discs. The CM-20DIS uses two disc supply spindles each of which can hold 150 (or 100) discs. Switching to the reserve stack is of course automatic and operators can safely refill discs without stopping the operation.

By using the two CM-20DIS units with a turnaround unit, the case can be rotated by 180° after disc 1 insertion by the first CM-20DIS, and disc 2 can be inserted by the next CM-20DIS. With an overlap unit that shifts the disc insertion position and the additional CM-20DIS units, you can handle up to 4-disc sets.

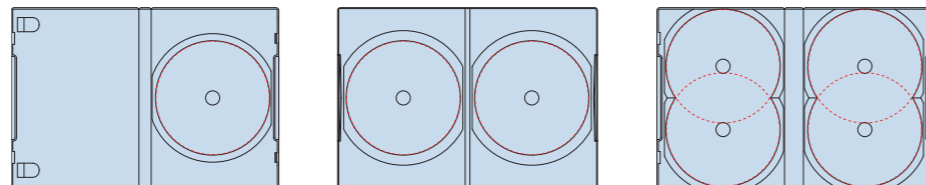
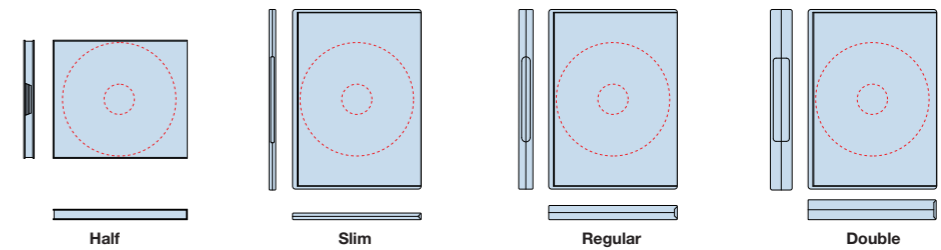

Photo: CM-20DIS



## CM-20CC CASE CLOSER

The Otari CM-20CC DVD case closer is designed to be placed after the disc/booklet inserting process of the DVD packaging line and it automatically closes DVD cases fed by the belt conveyor. The CM-20CC supports various types of DVD cases such as regular, slim, Warner, double and half case (half cases require installation of a conversion kit).



## CM-100DC/DC2 DISC CHECKER

The Otari CM-100DC and CM-100DC-2 are designed to be placed near the end of a DVD packaging line. The machines are used to confirm that DVD discs are set in the closed cases supplied on the conveyor. The CM-100DC detects disc presence in the case and the CM-100DC-2 detects whether each case contains only one disc. Cases containing one disc are passed to the downstream conveyor and rejected cases are dropped from the machine. Some cases may require setup change.



## CM-60CS CASE STACKER

The Otari CM-60CS DVD Case Stacker has been designed to be placed near the end of a DVD packaging line and it makes stacks (bundles) of DVD cases in five steps; the maximum stack size is 25 cases. The stacker can hold up to 150 cases (tall cases). A stack size of five cases is effective for avoiding errors such as miscounting, and for controlling product amount. Various types of cases can be handled: regular, slim, Warner and half cases (half cases require installation of an optional kit).